

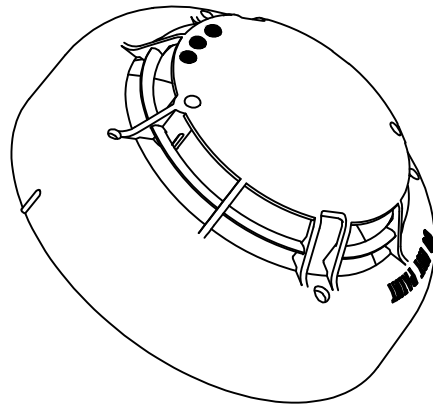

# Technical Bulletin Analog 2

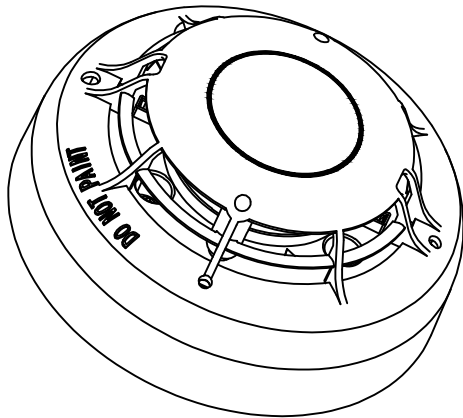
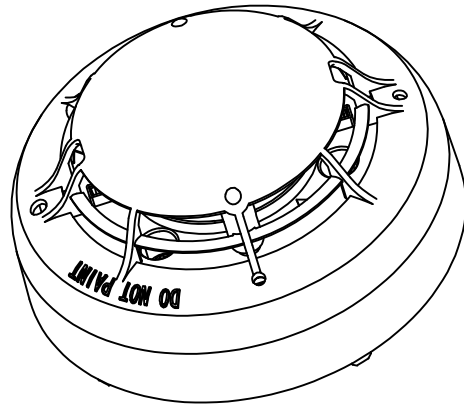
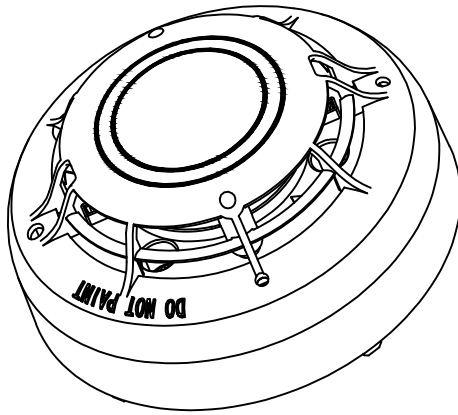

## Introduction

These instructions apply to all sensors listed on this Technical Bulletin for maintaining, cleaning and testing. Failure to following these instructions may result in the failure of the sensors to initiate an alarm condition. Hochiki America Corporation is not responsible for sensors that have been improperly maintained, cleaned or tested.

## Features

- ALN-V photoelectric smoke chamber detects smoldering/fast-flaming fires
- ATJ-EA combination fixed/rate of rise heat sensing element detects both fixed/rate of rise temperature
- ACC-V multi-criteria photoelectric smoke chamber and heat sensing element detects smoldering or fast-flaming fires and fixed temperature
- ACD-V multi-criteria photoelectric smoke chamber, combination fixed/rate of rise heat sensing element, and carbon monoxide (CO) detects smoldering/fast-flaming fires, fixed/rate of rise temperatures, and poisonous carbon monoxide (CO) gas.
- The combination of a high signal-to-noise ratio and sensitivity stability make this sensor effective in a wide range of environmental conditions
- User programmable alarm thresholds
- A reliable and fully digital transmission method, which is highly immune to noise
- The control panel is able to verify the status of any device. Whether the device is dirty or approaching an alarm condition, it can make this determination routinely
- It is possible to assign a priority to any device that is deemed necessary by the nature of the systems design
- There is an interrupt sequence, which can assign priority to fire and other similar signals

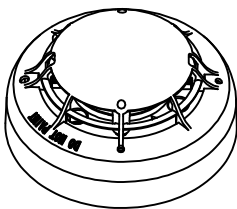

**ALN-V**

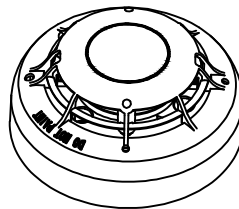

**ATJ-EA**

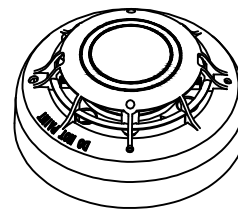

**ACC-V**

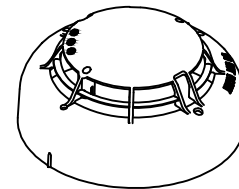

**ACD-V**

SENSOR SPECIFICATIONS				
CATEGORY	SMOKE SENSORS	HEAT SENSOR	MULTI-CRITERIA SENSORS	
Model	ALN-V	ATJ-EA	ACC-V	ACD-V
Operating Voltage Range (S-SC)	17 - 39.5 VDC	24 - 41.0 VDC	17 - 39.5 VDC	24 - 41.0 VDC
Sensitivity Range	300 fpm: 0.70 - 4.00 %/ft* 2000 fpm: 0.70 - 3.86 %/ft** 4000 fpm: 0.70 - 2.65 %/ft**	Fixed: 135 - 190°F Rate of Rise: 15°F/m	300 fpm: 0.70 - 4.00 %/ft* 2000 fpm: 0.70 - 3.86 %/ft** 4000 fpm: 0.70 - 2.65 %/ft**	300 fpm: 0.77 - 3.47 %/ft* 2000 fpm: 0.77 - 3.56 %/ft** 4000 fpm: 0.77 - 4.00 %/ft** Fixed: 135 - 150°F (57-65°C) Rate of Rise: 15°F/m (8.3°C)
Current Consumption (S-SC)	450µA Typical 540µA Maximum	350µA Typical 500µA Maximum	450µA Typical 540µA Maximum	600µA Maximum 30 mA Max. Alarm Current
Device Type Code	88 Hex	98 Hex	D8 Hex	D9 Hex
Operating Temperature	14 - 122°F (-10 - 50°C)	14 - 122°F (-10 - 50°C)	14 - 122°F (-10 - 50°C)	14 - 122°F (-10 - 50°C)
UL Listed Ambient Temperature	32 - 120°F (0 - 49°C)	32 - 120°F (0 - 49°C)	32 - 120°F (0 - 49°C)	32 - 120°F (0 - 49°C)
Storage Temperature	-4 - 140°F (-20 - 60°C)	-4 - 140°F (-20 - 60°C)	-4 - 140°F (-20 - 60°C)	-4 - 122°F (-20 - 50°C)
Dimension	3.94"D X 1.56"H	3.94"D X 1.56"H	3.94"D X 1.56"H	3.94"D X 1.56"H
Environment	Indoor Use Only	Indoor Use Only	Indoor Use Only	Indoor Use Only
Visual Alarm/ Power Indicator	Dual LED	Dual LED	Dual LED	Dual LED
CO Sensor Response Time	N/A	N/A	N/A	70 ppm 60 - 240 min.
Testing Equipment	Testifire 1000 or 2000 w/TS3	Testifire 1000	Testifire 1000 or 2000 w/TS3	Testifire 1000 or 2000 w/TS3 & TC3

## Placement of sensors

This section explains how to determine the number of sensors are needed, and where to place them. By following the guidelines listed in the NFPA 72, base the number and location of sensors on an engineering survey of the area to be protected.

### Factors to consider:

- Contents to be protected
- Type of construction and use of structure
- Human occupancy
- Burning characteristics of contents
- Space involved
- Height of ceiling
- Surface condition of ceiling
- Total area
- Air movement (stratification)
- Vent location (velocities and dilution)
- Deflections and obstructions

### Sensor Location:

- One smoke sensor covers 450 to 900 square feet
- One heat sensor covers up to 2500 square feet
- Consider local conditions and codes along with engineering evaluations to determine the proper spacing and specification

WARNING: Heat sensors are not life safety devices. Smoke sensors are recommended where life safety is a factor

### Examples:

1. You may use 30' spacing on smooth ceilings for smoke sensors
2. You may use 70' spacing on smooth ceilings for heat sensors
3. Beams or other obstructions extending more than 18" below the ceiling reduce the effective range of the sensors. Such obstruction should designate a new separation point and be considered a border for a new section.
4. Beams or other obstructions extending more than 8" but less than 18" require reduced spacing at the perpendicular of the obstructions.

NOTE: For information on differing styles of construction consult the NFPA handbook, section 72.

WARNING: Do not install Hochiki smoke sensors in the following areas:

- Where temperatures are likely to exceed 100°F or fall below 32°F
- Closer than 4" to any side wall
- Where forced ventilation can dilute the smoke from a fire
- In known areas of combustion such as kitchens or furnace rooms

## Testing

Photoelectric/Heat/Multi-Criteria Sensors:

For a smoke sensor to operate efficiently, the combustion products must enter the outer chamber. Air flow, stratification, velocity, stagnation, and migration all affect the efficiency and accuracy of the sensor. Use an air flow meter to determine the movement of the air within a structure. Field testing equipment is available from Hochiki America for testing the function of the sensors. Consult local codes and ordinances for maintenance requirements. Hochiki America Corporation recommends a bi-annual functional testing and visual inspection. See the Tester section in this Technical Bulletin and the control panel manual for additional information.

## BOTTOM VIEW

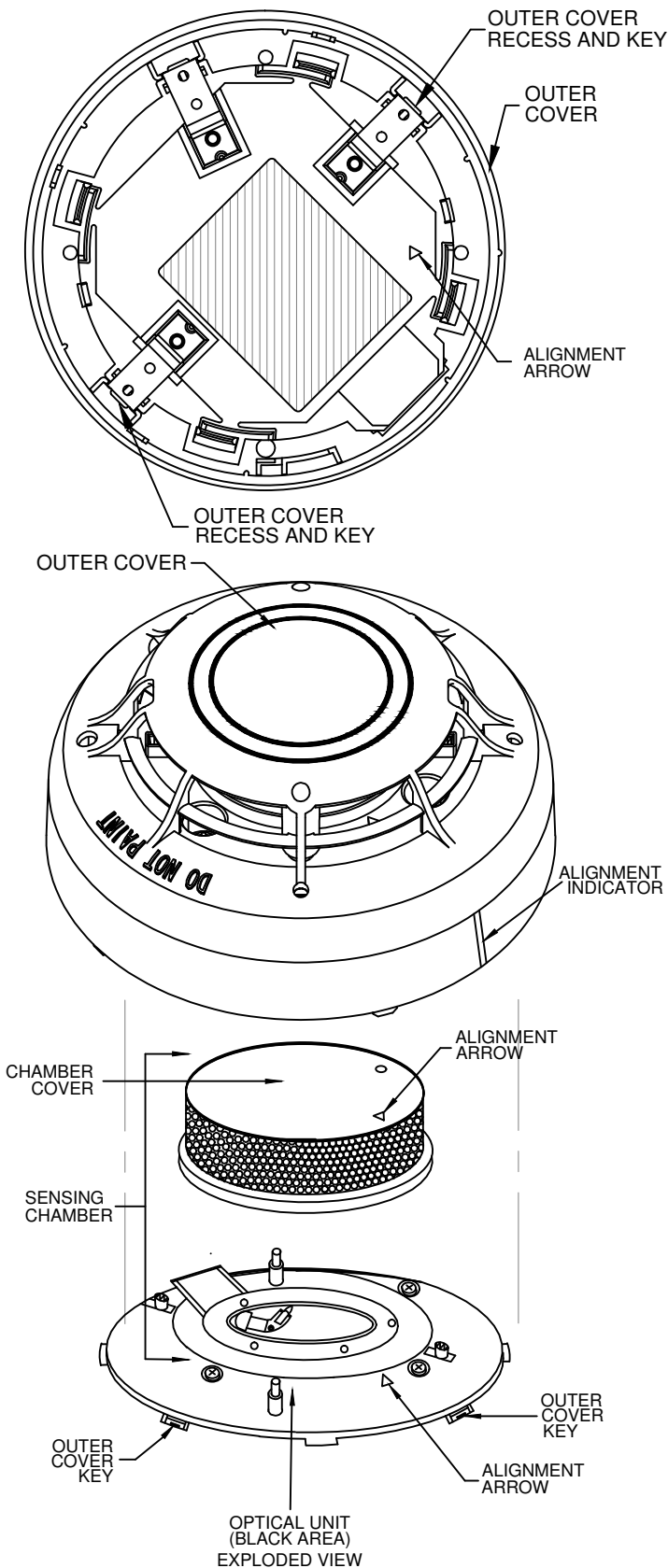

## Manual Cleaning Procedures

This section explains how to clean the ALN-V, ACC-V, and ACD-V sensors.

### Tools needed:

- Hochiki America's cover removal tool (CRT)
- Small soft bristled paint brush
- Denatured alcohol
- Compressed air duster

NOTE: Use only lint-free materials when cleaning the chambers of the photoelectric smoke sensor. Use of fibrous materials may result in nuisance alarm.

### Remove & Disassemble the Sensor:

1. Remove the sensor from its attached base
2. Disassemble sensor by following the CRT procedures found on page 4 of this Technical Bulletin

### Clean the Sensor:

CAUTION: Do not remove the insect screen from the chamber cover

1. Remove the outer cover of the sensor as specified on page 4
2. Place the sensor in the palm of your left hand and grasp the chamber cover with your right hand. Twist the chamber cover counter-clockwise until the Cover Tabs clear the Tab lock. Lift and separate the chamber cover from the optical unit
3. Swab the optical unit with denatured alcohol using a small soft bristled paint brush
4. Clean the chamber cover and the outer cover in the same manner

### Clean the Sensor:

1. Locate the alignment arrows on both the chamber cover and the optical unit
2. Set the chamber cover onto the optical unit while making sure that alignment arrows are aligned with one another
3. Press until the cover snaps into place
4. Match the alignment indicator with the alignment arrow on the back of the sensor
5. With the alignment indicator aligned with the alignment arrow, press firmly on the back of the sensor. The sensor will snap into the outer cover. The sensor is now ready to be returned to the base from which it was removed
6. The sensor should be re-tested by following the test procedure found in the control panel manual

NOTE: If after testing, the sensor is not working within the prescribed range then return it to the manufacturer for servicing

## Cover Removal Procedures

This section explains how to remove the outer cover from the ALN-V, ATJ-EA, ACC-V, and ACD-V sensors by using the cover removal tool (CRT).

Tools needed:

- Hochiki America's cover removal tool (CRT)

Remove & Disassemble the Sensor:

1. Place the sensor to be disassembled on the CRT as shown
2. Push the CRT. The sensor will automatically pop open
3. The contact blades on the sensor will engage on the CRT
4. Grasp the sensor firmly and rotate the CRT counter-clockwise (approximately 10°)
5. After the cover have been removed, refer to the sensor cleaning procedures to clean and reassemble the sensor

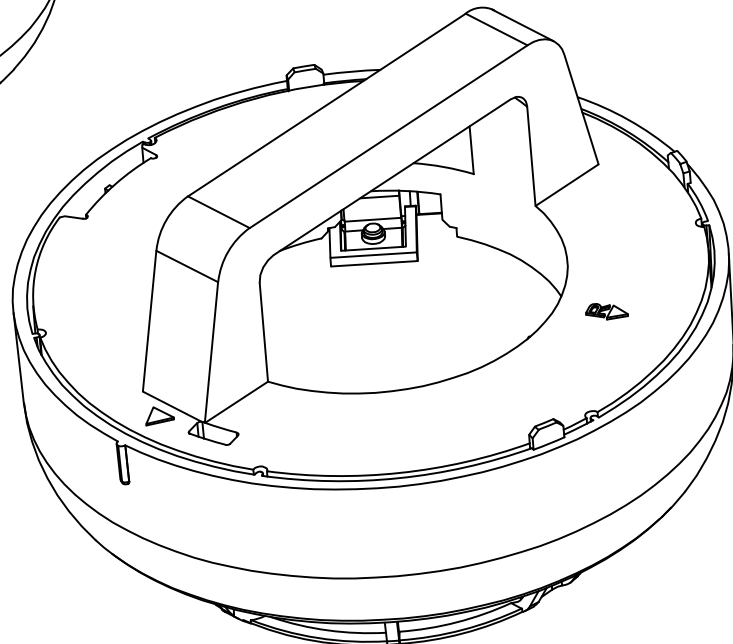
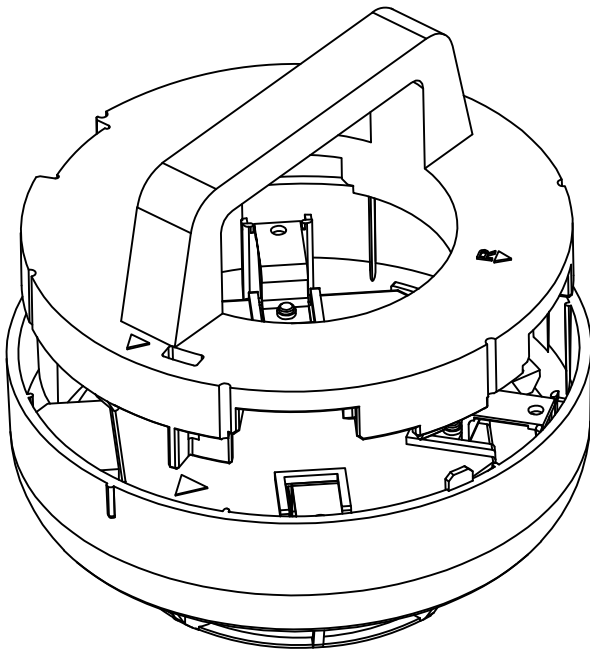
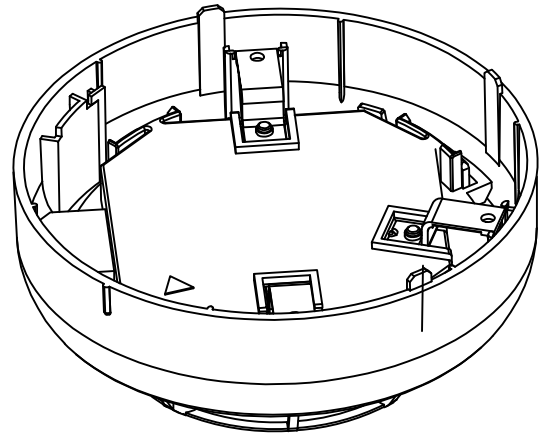
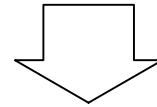
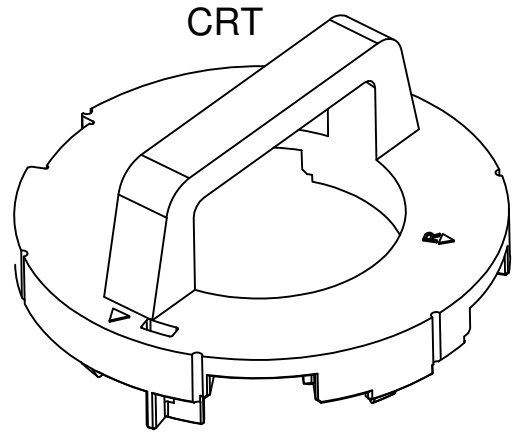

Testfire 1000 or 2000 with TS3 or TC3:

1. Insert the battery baton, hold the Testfire head unit by the handle and depress the upper spring button on the battery baton. Align the button with the location hole in the handle and push the battery baton into the handle until the button springs up through the location hole.
2. Insert the other end of the battery baton into the Solo access pole and depress the lower spring button. Align it with the location hole and push the battery baton further into the pole until the button springs up through the hole.
3. Remove the capsule from its outer carton and Anti-Static bag.
4. Remove the spring clip protector cap from the new capsule.
5. Holding the capsule by spring clips with the label on the underside, carefully insert the new capsule into the capsule port. Push it into position, ensuring that the clips spring out positively on both sides of the capsule.
6. Close the access cover securely.
7. Program the tester to the following options available: Smoke, Heat or CO.
8. Raise Testfire over the sensor. The sensor should touch the base of the inner clear cup.
9. Lower Testfire from the sensor.

Testfire's LED Indications:

- |                                 |  |
|---------------------------------|--|
| Blue Solid:                     | Smoke test in progress   |
| Red Solid:                      | Heat test in progress  |
| Green Solid:                    | CO test in progress  |
| Green Slow Flashing:            | Standby mode   |
| Green Fast Flashing:            | Operational mode   |
| Red Flashing:                   | Battery needs charging, but still operational  |
| Alternating Red/Green Flashing: | Timeout indication (after 2 minutes of continuous testing on one stimulus or combination of stimuli) |
| Red Solid:                      | Error  |
| Green Solid:                    | CO cooling   |
| Alternating Red/Green:          | CO cooling phase wait until standby mode status before continuing to test CO                         |

The Hochiki ACD-V is a Multi Criteria Sensor. The ACD-V is capable of Smoke, Heat and CO Detection individually along with many criteria combinations based upon the activation mode setting of the detector (the activation mode is set through panel programming). To perform the detector test(s), the sensor must first be placed in an individual Activation Mode which will allow detection based upon a single criteria. The single criteria activation mode may or may not be the normal operation activation mode of this particular sensor. Once sensor testing has been completed; it is essential that the activation mode be restored to the original setting. Prior to testing any sensor, care should be exercised to ensure proper disabling of live signals and notification circuits of the Fire Alarm Control Panel. Failure to exercise this procedure may result in false alarm signals which could place life and property in jeopardy.

To view or alter Activation Modes on the FireNET series of Panels (Please consult your manufacture for other panels):

- Enter Level 2 password or Insert "Enable Access" Key > Turn Key to right. You are Now in Access Level 2.
- Arrow Button down to Access Level 3.
- Enter Level 3 password: \_ \_ \_ \_
- Go to: Edit Configuration > Edit Device Attribute > Edit Device on Loop: Select ACD-V (Enter) > Edit Modes > Select:
  - DAY: +S+FT+RoR+CO+COHb (Enter)
  - NIGHT: +S+FT+RoR+CO+COHb (Enter)

Using the Testifier 2000, all three Criteria of the Sensor can be tested individually.



1. Inner Clear Cup
2. Platform
3. Clear Cup
4. Bellows
5. RFID Antenna\*\*
6. Infrared Beam
7. Main Duct for Heat, Smoke and CO\*
8. Testfire 100 RFID Bluetooth® Module\*\*
9. Smoke Capsule TS3
10. CO Capsule TC3\*
11. USB Port (on rear of unit)
12. User Interface Display (LCD)
13. 'Test Type' LED
14. 'Status' LED
15. Smoke Capsule Access Cover
16. CO Capsule Access Cover\*
17. Adjustable Handle
18. Battery Baton
19. Infrared Remote Control Receivers

\* Depending on model specification \*\* Future option.



Testfire 1000 Series Head Unit Smoke & Heat

Testfire 2000 Series Head Unit Smoke, Heat & CO

## Programmer Operating Procedure

This section explains how to program the sensor's address using the TCH-B100 and TCH-B255 hand held programmer. The hand held programmer is designed for use with Hochiki's DCP protocol supported SLC devices.

### Features:

- TCH-B100/-B255 is a compact design and easy to use
- Provides address setting and reading
- Diagnostic ability by displaying the analog value in real-time
- Uses 9VDC battery
- Automatically increments to the next address for addressing multiple sensors
- Automatically switches the power to off after use

### Programming Buttons:

**Left Gray Button:** Power on. Automatically reads the address of a sensor. Subsequent operations will advance the device address by ten.

**Right Gray Button:** Power off. Advances the device address by one. Stores the displayed address to the device and is used to read the sensor's analog values.

### Address Setting:

1. Install sensor onto programmer, ensuring that the sensor protrusion aligns with the programmer grooves
2. Press the left gray button to switch programmer to on. A battery check message will appear followed by the device address (un-programmed sensors will read a default address of 127 or 255)
3. Set the required address by incrementing the left and right gray buttons (the display will show three red flashing dots if the address being programmed is different from the device's current address)
4. When the desired address is present, press the red button to store the address. The three red dots on the display will no longer be present

### Reading Analog Value:

1. Install the sensor and power up programmer as previously described
2. Press the red button. An "A" will appear on the display followed by the analog value. This value will be continuously updated for three minutes or until the unit is turned off
3. The "ALG" photoelectric sensor should display a value between 56-63

### Display Message:

**bAt:** On power up (check battery). 3000 address can be set in low battery condition

**E0:** Attempting to set an address beyond 127 or 255

**E1:** Attempting to program an address with no device connected

**E2:** Can not find device after power up

**E3:** Invalid sensor response

**E4:** Can not find the device program

**E5:** Device read error

**E6:** Fail to read analog value

### CO Sensor Lifetime:

Replace the ACD-V sensor in the following cases:

1. Control panel indicates the end of life trouble (10 years from the initial power up)
2. Indicated time on the product label

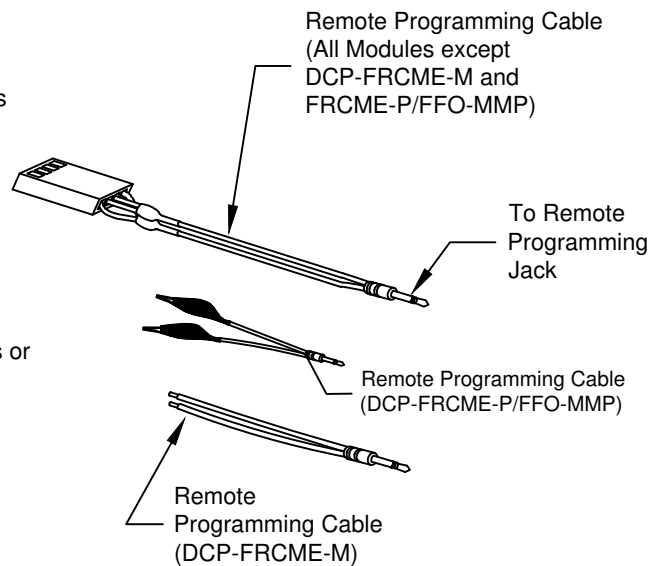
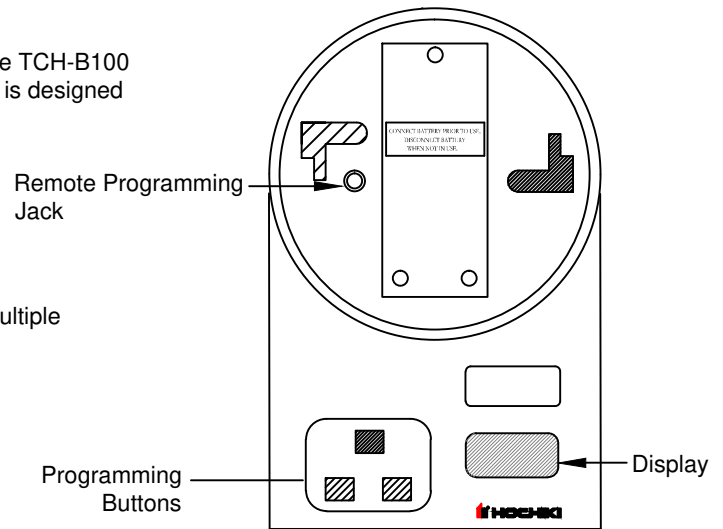

## Programmer Operating Procedure

This section explains how to program the sensor's address using the TCH-B100 and TCH-B255 hand held programmer. The hand held programmer is designed for use with Hochiki's DCP protocol supported SLC devices.

### Features:

- TCH-B100/-B255 is a compact design and easy to use
- Provides address setting and reading
- Diagnostic ability by displaying the analog value in real-time
- Uses 9VDC battery
- Automatically increments to the next address for addressing multiple sensors
- Automatically switches the power to off after use

### Programming Buttons:

**Left Gray Button:** Power on. Automatically reads the address of a sensor. Subsequent operations will advance the device address by ten.

**Right Gray Button:** Power off. Advances the device address by one. Stores the displayed address to the device and is used to read the sensor's analog values.

### Address Setting:

1. Install sensor onto programmer, ensuring that the sensor protrusion aligns with the programmer grooves
2. Press the left gray button to switch programmer to on. A battery check message will appear followed by the device address (un-programmed sensors will read a default address of 127 or 255)
3. Set the required address by incrementing the left and right gray buttons (the display will show three red flashing dots if the address being programmed is different from the device's current address)
4. When the desired address is present, press the red button to store the address. The three red dots on the display will no longer be present

### Reading Analog Value:

1. Install the sensor and power up programmer as previously described
2. Press the red button. An "A" will appear on the display followed by the analog value. This value will be continuously updated for three minutes or until the unit is turned off
3. The "ALG" photoelectric sensor should display a value between 56-63

### Display Message:

**bAt:** On power up (check battery). 3000 address can be set in low battery condition

- E0: Attempting to set an address beyond 127 or 255  
 E1: Attempting to program an address with no device connected  
 E2: Can not find device after power up  
 E3: Invalid sensor response  
 E4: Can not find the device program  
 E5: Device read error  
 E6: Fail to read analog value

### CO Sensor Lifetime:

Replace the ACD-V sensor in the following cases:

1. Control panel indicates the end of life trouble (10 years from the initial power up)
2. Indicated time on the product label

